

Hanson Red Bank

Atherstone Road
Measham
Swadlincote
Derbyshire DE12 7EL
Tel: 01530 270333 Fax: 01530 270542
e-mail: redbank-manufacturing@dial.pipex.com
website: www.redbank-manufacturing.co.uk



Agrément Certificate
00/3697
Product Sheet 2

LOCKCLAD RAINSCREEN CLADDING SYSTEMS

LOCKCLAD SIGMA RAINSCREEN CLADDING SYSTEM

PRODUCT SCOPE AND SUMMARY OF CERTIFICATE

This Certificate relates to the Lockclad Sigma Rainscreen Cladding System, an open-jointed, back-ventilated and drained cladding for use where short to medium spans (typically 1 m) between vertical support rails will suffice (Sigma = short span system).

AGRÉMENT CERTIFICATION INCLUDES:

- factors relating to compliance with Building Regulations where applicable
- factors relating to additional non-regulatory information where applicable
- independently verified technical specification
- assessment criteria and technical investigations
- design considerations
- installation guidance
- regular surveillance of production
- formal three-yearly review.

KEY FACTORS ASSESSED

Strength and stability — As the cladding is open-jointed, the substrate wall must be able to take the full wind load (see section 5).

Behaviour in relation to fire — The tiles have a Class 0 fire rating under the UK Building Regulations (see section 6).

Air and water penetration — The cladding is not airtight or watertight, but is intentionally open-jointed (see section 7).

Maintenance — The tiles are generally self-cleaning (see section 8).

Durability — The system has a design life in excess of 25 years (see section 9).



The BBA has awarded this Agrément Certificate to the company named above for the system described herein. This system has been assessed by the BBA as being fit for its intended use provided it is installed, used and maintained as set out in this Certificate.

On behalf of the British Board of Agrément

Brian Chamberlain
Head of Approvals — Engineering

Greg Cooper
Chief Executive

Date of First issue: 16 February 2009

Originally certificated on 29 March 2000.

The BBA is a UKAS accredited certification body — Number 113. The schedule of the current scope of accreditation for product certification is available in pdf format via the UKAS link on the BBA website at www.bbacerts.co.uk

Readers are advised to check the validity and latest issue number of this Agrément Certificate by either referring to the BBA website or contacting the BBA direct.

British Board of Agrément
Bucknalls Lane
Garston, Watford
Herts WD25 9BA

©2009

tel: 01923 665300
fax: 01923 665301
e-mail: mail@bba.star.co.uk
website: www.bbacerts.co.uk

Regulations

In the opinion of the BBA, the Lockclad Sigma Rainscreen Cladding System, if used in accordance with the provisions of this Certificate, will meet or contribute to meeting the relevant requirements of the following Building Regulations:



The Building Regulations 2000 (as amended) (England and Wales)

Requirement:	A1	Loading
Comment:		The claddings are acceptable for use as set out in sections 3.2 and 5.1 to 5.8 of this Certificate.
Requirement:	B4(1)	External fire spread
Comment:		The claddings are judged to meet the Class 0 requirements. See sections 6.1 to 6.5 of this Certificate.
Requirement:	C2(b)(c)	Resistance to moisture
Comment:		The claddings are not watertight, but will resist the passage of rainwater to the supporting structure. See sections 7.1 to 7.5 of this Certificate.
Requirement:	Regulation 7	Materials and workmanship
Comment:		The claddings are acceptable. See sections 9.1 to 9.4 and the <i>Installation</i> part of this Certificate.



The Building (Scotland) Regulations 2004 (as amended)

Regulation:	8(1)(2)	Fitness and durability of materials and workmanship
Comment:		The system can contribute to a construction satisfying this Regulation. See sections 8.1 to 8.3 and 9.1 to 9.4 and the <i>Installation</i> part of this Certificate.
Regulation:	9	Building standards – construction
Standard:	1.1(a)(b)	Structure
Comment:		The claddings as set out in section 3.2 and 5.1 to 5.8 are acceptable.
Standard:	2.1	Compartmentation
Comment:		The claddings can contribute to satisfying this Standard, with reference to clause 2.1.15 ⁽²⁾ . See sections 6.1 to 6.5 of this Certificate.
Standard:	2.2	Separation
Comment:		The claddings can contribute to satisfying this Standard, with reference to clauses 2.2.7 ⁽²⁾ and 2.2.10 ⁽¹⁾ . See sections 6.1 to 6.5 of this Certificate.
Standard:	2.4	Cavities
Comment:		The claddings can contribute to satisfying this Standard, with reference to clauses 2.4.2 ⁽¹⁾⁽²⁾ , 2.4.3 ⁽²⁾ , 2.4.7 ⁽¹⁾ and 2.4.9 ⁽²⁾ . See sections 6.1 to 6.5 of this Certificate.
Standard:	2.5	Internal linings
Comment:		The claddings are classified as ‘non-combustible’ and so are unrestricted by this Standard, with reference to clause 2.5.1 ⁽¹⁾⁽²⁾ . See sections 6.1 to 6.5 of this Certificate.
Standard:	2.6	Spread to neighbouring buildings
Comment:		The claddings are classified as ‘non-combustible’ and therefore are unrestricted under this Standard, with reference to clauses 2.6.4 ⁽¹⁾⁽²⁾ , 2.6.5 ⁽¹⁾ and 2.6.6 ⁽²⁾ . See sections 6.1 to 6.5 of this Certificate.
Standard:	2.7	Spread on external walls
Comment:		The claddings are classified as ‘non-combustible’ and therefore are unrestricted under this Standard, with reference to clause 2.7.1 ⁽¹⁾⁽²⁾ . See sections 6.1 to 6.5 of this Certificate.
Standard:	3.10	Precipitation
Comment:		The claddings are not watertight, but will resist the passage of rainwater to the supporting structure, with reference to clauses 3.10.1 ⁽¹⁾⁽²⁾ , 3.10.5 ⁽¹⁾⁽²⁾ and 3.10.6 ⁽¹⁾⁽²⁾ . See sections 7.1 to 7.5 of this Certificate.
Regulation:	12	Building standards – conversions
Comment:		All comments given for this system under Regulation 9, also apply to this Regulation, with reference to clause 0.12.1 ⁽¹⁾⁽²⁾ and Schedule 6 ⁽¹⁾⁽²⁾ . (1) Technical Handbook (Domestic). (2) Technical Handbook (Non-Domestic).



The Building Regulations (Northern Ireland) 2000 (as amended)

Regulation:	B2	Fitness of materials and workmanship
Comment:		The claddings are acceptable. See sections 9.1 to 9.4 and the <i>Installation</i> part of this Certificate.
Regulation:	B3(2)	Suitability of certain materials
Comment:		The claddings are acceptable. See sections 8.1 to 8.3 of this Certificate.
Regulation:	C4	Resistance to ground moisture and weather
Comment:		The claddings are not watertight, but will resist the passage of rainwater to the supporting structure. See sections 7.1 to 7.5 of this Certificate.
Regulation:	D1	Stability
Comment:		The system is acceptable for use when installed in accordance with this Certificate. See sections 3.2 and 5.1 to 5.8 of this Certificate.
Regulation:	E5	External fire spread
Comment:		The claddings are judged to meet the Class 0 requirements. See sections 6.1 to 6.5 of this Certificate.

Construction (Design and Management) Regulations 2007

Construction (Design and Management) Regulations (Northern Ireland) 2007

Information in this Certificate may assist the client, CDM co-ordinator, designer and contractors to address their obligations under these Regulations.

See section: 2 Delivery and site handling (2.5).

Non-regulatory Information

NHBC Standards 2008

NHBC accepts the use of the Lockclad Sigma Rainscreen Cladding System, when installed and used in accordance with this Certificate, in relation to *NHBC Standards*, Chapter 6.9 *Curtain walling and cladding*.

Zurich Building Guarantee Technical Manual 2007

In the opinion of the BBA, the Lockclad Sigma Rainscreen Cladding System, when installed and used in accordance with this Certificate, satisfies the requirements of the *Zurich Building Guarantee Technical Manual*, Section 4 *Superstructure*, Sub-sections *External walls*.

General

This Certificate relates to the Lockclad Sigma Rainscreen Cladding System, an open-jointed, back ventilated and drained cladding comprising clay tiles hung on aluminium support rails.

The system is for use where short to medium spans (typically 1 m) between vertical support rails will suffice (Sigma = short span system).

It is essential that the cladding is installed in accordance with the manufacturer's instructions and the requirements of this Certificate.

Technical Specification

1 Description

1.1 Lockclad Sigma Rainscreen Cladding System is an open-jointed, back-ventilated and drained system comprising clay tiles hung on aluminium support rails.

1.2 The tiles are of one basic design and thickness (see Figure 1), but vary in width, from 210 mm to 400 mm, and face height, from 175 mm to 240 mm. Mitred tiles are available for corners.

1.3 The range of tiles covers three blends of clay and five colours (see Table 1). For all colours there will be some tile to tile variation in shade, due to the natural origin of the product.

1.4 The tiles weigh from 44 kgm⁻² to 47 kgm⁻², have water absorption values in the range of 5% to 8%, and flexural strength in excess of 2 kN.

1.5 The tiles are formed by vacuum extrusion and fired in an automated kiln at around 1000°C.

1.6 Quality control is exercised during the production of the tiles; checks include appearance, dimensions, weight, moisture absorption and behaviour under freeze-thaw cycling.

1.7 The components of the aluminium support system, bought-in to an agreed specification, are shown in Figure 2. The function of the components is detailed in Table 2. In brief, the tiles fit between horizontal rails fixed to vertical rails on the substrate wall. There is a 10 mm baffled opening between tiles horizontally and either a 2 mm opening or 8 mm loose-fitting, black polypropylene strip between tiles vertically. The fixing of the horizontal rails to the vertical rails, the specification of the vertical rails, and the fixing of vertical rails to the substrate, all of which must be approved by an appropriately qualified engineer, are outside the scope of this Certificate, as are top, side, corner, bottom and other finishing trims.

Figure 1 Lock Tile

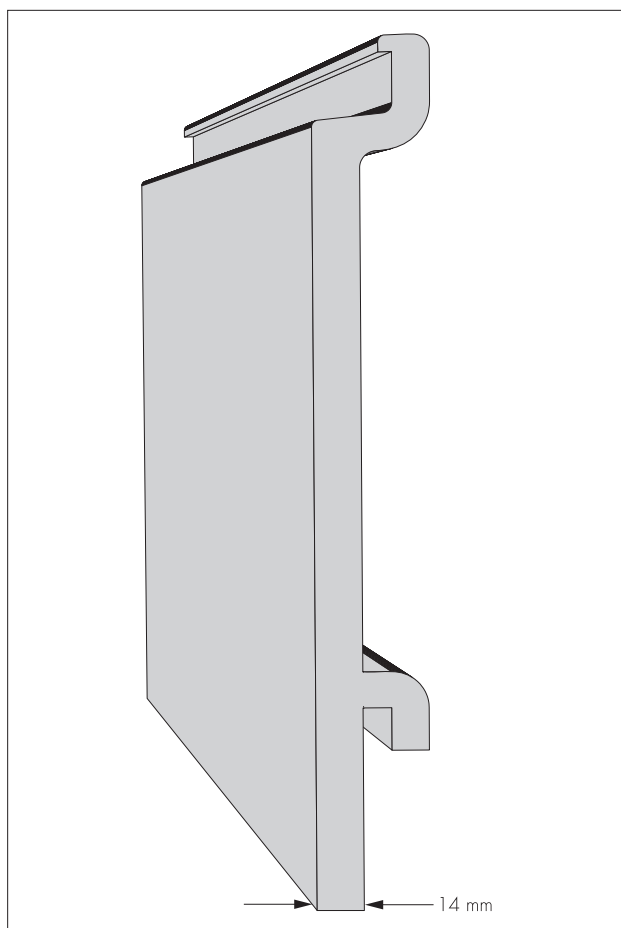

Table 1 Blends and colours of tiles

Clay blend	Colour
Terracotta	Red
Buff	Buff, Antique
Slate body	Slate, Brown

Table 2 Aluminium support system

Component	Function	Material
Sigma rail	Main horizontal support rail	Aluminium alloy: 6063 T6 BS EN 12020 : 2001
Top rail	Top horizontal support rail (alternative to Sigma rail where trim or overhang will not conceal exposed part of Sigma at top of installation)	Aluminium alloy: 6063 T6 BS EN 12020 : 2001
Bottom rail	Bottom horizontal support rail (alternative to Sigma rail where part of the bottom leg of the bottom tile needs to be removed to suit the dimensions of the installation)	Aluminium alloy: 6063 T6 BS EN 12020 : 2001
Lockclip 1	To provide tight fit at bottom of tile and 2 mm vertical space between tiles	Polypropylene copolymer (black)
Lockclip 2	As above, but to be used about every fifth tile along a row (to allow access and replacement of tiles), and for last tile of the row	Polypropylene copolymer (black)
Lockspacer 2	For use with 2 mm spaced tiles, to prevent water splashing behind cladding from rail at tile corner joints	Polypropylene copolymer (black)
Lockspacer 8	As above but for 8 mm spaced tiles	Polypropylene copolymer (black)
Top/bottom bar	As above but used on top/bottom row of tiles	Polypropylene copolymer (black)
8 mm bar	To be fitted between two Lockspacer 8 units to restrict water ingress between tiles	Polypropylene copolymer (black)

2 Delivery and site handling

2.1 Tiles are delivered to site shrink-wrapped on wooden pallets, with heavy-duty cardboard between each layer of tiles. Pallets should be stored on level ground and not stacked.

2.2 Each pallet of tiles bears a label with product details (such as type, size, quantity) and the edge of each tile is marked with an identification code including a manufacturing reference.

2.3 Rails are delivered to site in timber stillages and Lockclips and spacers in cardboard boxes.

2.4 Packs of rails should be stacked horizontally on sufficient bearers to prevent distortion, to a maximum height of 1 m. Other components should be stored in a safe weatherproof store.

2.5 Tiles should be handled with care to avoid damage or breakage. Care is required when handling long lengths of rail, particularly at height.

Figure 2 Components of the support system

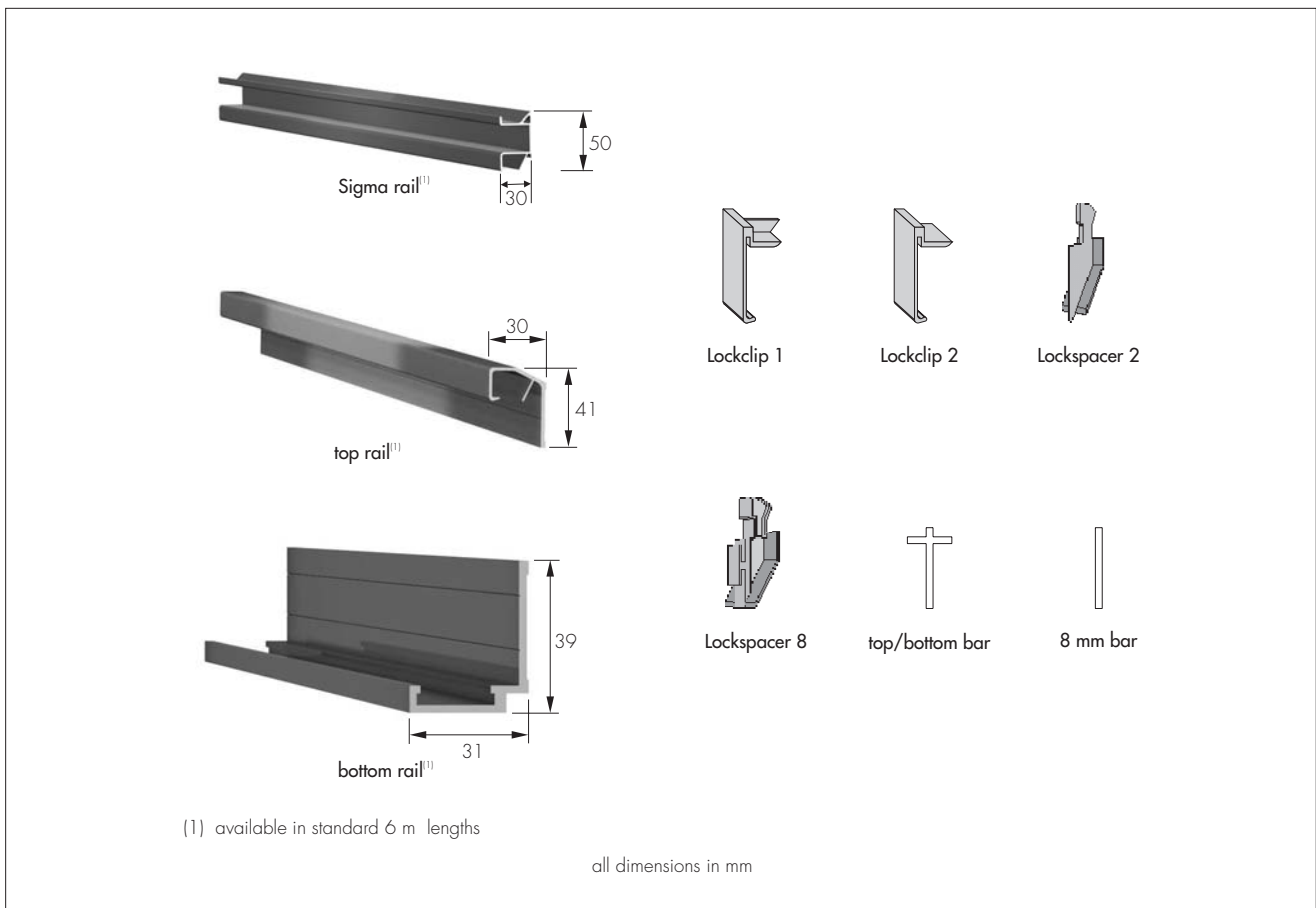

Assessment and Technical Investigations

The following is a summary of the assessment and technical investigations carried out on the Lockclad Sigma Rainscreen Cladding System.

Design Considerations

3 General

3.1 Ventilation and drainage must be provided behind the cladding suitable for a back-ventilated and drained system. A minimum of 25 mm wide air space is specified behind the back face of the horizontal aluminium support rail and minimum ventilation opening of 10 000 mm² and 20 000 mm² per metre run at the top and bottom of the installation, respectively. The ventilation openings should be suitably protected or baffled to prevent the ingress of birds, vermin and rain. The openings around each tile will provide additional ventilation and drainage pathways.



3.2 The wall and sub-frame to which the cladding is fixed should be structurally sound and constructed in accordance with the requirements of the relevant building regulations and national standards. The components of the sub-frame system should be durable and corrosion resistant.

3.3 The wall to which the cladding is fixed should be watertight and preferably airtight and resistant to the transmission of sound.

3.4 Insulation behind the cladding needs to be suitably fixed to the inner leaf to resist the forces of wind suction incident upon them as a result of the open joints of the cladding. Insulation should be of a rigid structure (eg boards). The ventilation pathway behind the cladding must not be allowed to become blocked nor the insulation moved into a position where it may be vulnerable to wetting.

3.5 The coefficient of expansion of aluminium is $23 \times 10^{-6} \text{ K}^{-1}$. As the horizontal rails are tight-fixed to vertical rails, a suitably qualified engineer needs to ensure that the sub-frame and substrate to which the horizontal rails are attached will accommodate the maximum thermal stresses that can be generated, eg by fixing to the horizontal rails a vertical support system that will allow some small (approximately 3 mm) lateral movement. It is recommended that installation is undertaken in temperatures between 5°C and 25°C. Installation in temperatures outside of this range should be avoided.

3.6 A suitably qualified engineer must check the design of each installation.

4 Practicability of installation

The product is suitable for installation by general building contractors provided that they have undergone appropriate training by the Certificate holder.

5 Strength and stability

Wind loading



5.1 The tiles have a flexural strength in excess of 2 kN and will withstand windloads likely to be encountered in the UK.

5.2 Load-span data for the main horizontal Sigma support rail and alternative top and bottom rails (for a span/200 deflection), at maximum 250 mm spacing (supporting the 240 mm face height tile), are given in Table 3.

5.3 Where the horizontal Sigma rails are used to support smaller tiles, the spans or wind pressures shown in Table 3 may be increased by the factors shown in Table 4.

Table 3 Load-span tables for horizontal Sigma aluminium support rails

Span (mm)	Maximum permitted wind pressure for L/200 deflection (kPa)	
	With full wind load on tiles/rails (no allowance for pressure equalisation)	With reduced wind loads on tiles/rails (allowing for pressure equalisation ⁽¹⁾)
Main Sigma rail:		
800	5.4	—
900	4.2	—
1000	3.3	—
1100	2.7	—
1200	2.3	6.8
1300	1.9	5.7
1400	1.6	4.8
Top rail:		
800	1.8	5.4
900	1.5	4.4
1000	1.2	3.7
1100	1.0	3.1
1200	0.9	2.6
Bottom rail:		
800	2.6	7.8
900	1.9	5.8

(1) For pressure equalisation:

- the inner wall must be airtight.
- the horizontal rail must be tight-fixed back to a vertical support rail over a washer of minimum 19 mm diameter. The fixing must be approved by a suitably qualified engineer.
- a soffit or equivalent must overhang the cladding at the top of the installation.
- the cavity behind the cladding must be closed vertically at the corners of the installation. If the corners are not closed, but other conditions for pressure equalisation apply, then pressure equalised loads may be assumed beyond 1.8 m from the corner; up to 1.8 m, full wind loads must be assumed.
- when used above an opening (eg on a wall above an open ground-floor car park) a suitable protruding baffle must be in place at the bottom of the installation to maintain pressure equalisation without blocking essential drainage/ventilation pathways.
- the cladding must be installed in accordance with manufacturer's instructions.
- a suitably qualified engineer must check the design and installation of the cladding.

5.4 For installations employing all three types of horizontal rail, on vertical support rails, running from top to bottom of the construction, the span between vertical rails must be that required for the weakest rail (ie the top rail). Alternatively, to accommodate the longer spans available to the main horizontal rail, then either additional intermediate supports (eg vertical rail offcuts) may be fixed behind top and bottom rails, or the main rail used throughout the construction.

5.5 The spans quoted in sections 5.2 to 5.4 will accommodate an L/600 dead deflection on the Sigma and bottom rail.

5.6 A cantilever length of L/5 is permitted at the end of a horizontal rail; where L is the span of the fully supported adjacent section.

5.7 As the cladding is open-jointed, the supporting wall must be able to take the full wind load.

5.8 Wind loads should be calculated in accordance with BS EN 1991-4 : 2005 and BS 6399-2 : 1997.

Table 4 Factors for increasing either span or wind pressure values given in Table 3

Grid spacing (mm)	Tile face height (mm)	Factor
235	225	1.06
220	210	1.14
210	200	1.19
200	190	1.25
185	175	1.35

Impact

5.9 In common with all clay tiles, the Lockclad tiles are susceptible to damage from hard body impacts. It is recommended that use of the product is restricted to locations where there is some incentive to exercise care and little chance of hard body impacts, such as detailed under categories C, D and F described in of BS 8200 : 1985, Table 2.

6 Behaviour in relation to fire



6.1 The tiles and aluminium support rails are non-combustible and as such have a Class 0 fire rating under the national Building Regulations.

6.2 The polypropylene Lockclips and Lockspacer components are largely protected by the tiles and, although the 8 mm wide polypropylene spacer bar extends between tiles vertically up the installation, it is considered that these plastic ancillary components are present in such relatively small amounts they are unlikely to significantly affect the overall fire performance of the cladding.

6.3 As a consequence of sections 6.1 and 6.2, the product may be regarded as suitable for installations where a Class 1 surface spread of flame is specified in accordance with BS 476-7 : 1997, and fire propagation indices of $I < 12$ and $i_1 < 6$ in accordance with BS 476-6 : 1989. On the basis of these data, therefore, the cladding may be considered to achieve the product performance classification of Class 0, as defined in the Building Regulations.

6.4 The incorporation of combustible material behind the cladding should be avoided wherever possible; any insulation should be non-combustible.

6.5 Cavity barriers should be incorporated behind the cladding as required under the national Building Regulations, but should not block essential ventilation pathways, for example by use of intumescent fire stops or overhanging incombustible breaks at each floor level.

7 Air and water penetration



7.1 The cladding is not airtight or watertight, but is intentionally open-jointed, back-ventilated and drained.

7.2 The inner wall supporting the cladding must be watertight.

7.3 A water-repellent insulant is recommended where insulation is used behind the cladding.

7.4 Provided that the inner wall is airtight, the effect of pressure equalisation will be such that rain will not be readily driven beyond the cladding and the majority of that which does will run down the back of one tile and out onto the front of the one below. Some rain, however, may be driven beyond the cavity behind the cladding and onto the inner leaf or insulation a minimum 25 mm behind the cladding support rail. However, the effect of pressure equalisation will be such that the volume of any such rain will be expected to be small and readily removed by the effects of drainage and ventilation in the cavity behind the cladding. To maintain the effect of pressure equalisation at the corner of the installation it is necessary to close the cavity behind the cladding over the full height of the installation. Otherwise a breather membrane up to 1.8 m from the corner or side should be used to protect the insulation.

7.5 Where pressure equalisation does not apply, insulation behind the cladding should be protected by a breather membrane.

8 Maintenance



8.1 The tiles are generally self-cleaning. Where necessary, a soft brush and copious amounts of clean water (eg a car hose-brush) may be used. Hard bristled brushes should not be used. For the removal of graffiti and other persistent stains the Certificate holder's advice should be sought. The removal of tiles and use of proprietary stain removers may be necessary.

8.2 Damaged tiles should be replaced as soon as practicable following the manufacturer's procedure:

- locate the closest tile on the same row supported on a Lockclip 2, identified with a small recess in the middle of the bottom edge of the clip (which should be centralised between two tiles)
- use the Lockslider tool (see Figure 3) to push the Lockclip under the adjacent tile away from the damaged one
- remove this tile and Lockclip 1 at the other side of the tile
- remove Lockclip 1 and tiles one by one along the row until the damaged tile is reached
- replace the damaged tile and reinsert the others⁽¹⁾ using standard installation procedure.

(1) Care should be taken to ensure that the shade of the replacement tile blends in with the installation.

8.3 Checks should be carried out periodically to ensure that ventilation and drainage pathways remain clear.

Figure 3 Installation tools

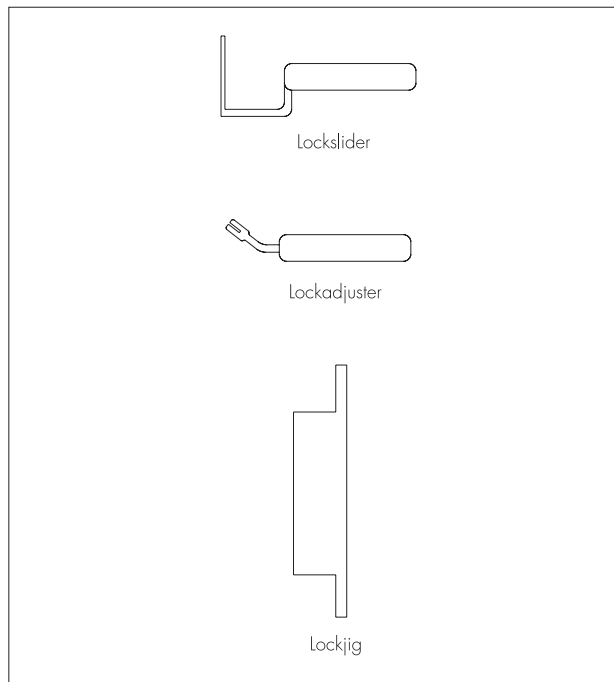

9 Durability



9.1 Freeze-thaw tests indicate that there will be no significant change in the physical properties of the tiles on ageing.

9.2 The tiles will have a life equivalent to known, good quality, clay tiles, when used in normal exposure conditions in the United Kingdom (ie in excess of 35 years).

9.3 The aluminium rails will have a lifetime at least commensurate with the tiles they are supporting.

9.4 Accelerated weathering tests indicate that the plastic fittings will have a life of at least 25 years in normal UK conditions.

9.5 After natural weathering some slight change in colour of the tiles may occur. However, this is not likely to be progressive.

Installation

10 General

10.1 The product must be installed in accordance with the manufacturer's recommendations, the requirements of this Certificate and the specification laid down by the consulting engineer.

10.2 Installers must be trained and approved by the Certificate holder.

10.3 Reference should be made to Figures 2, 3 and 4, Table 2 and section 1.7 when reading the procedural details given in section 11.

10.4 As colour variation in shade occurs within and between batches, care needs to be taken to achieve the desired variation on the finished wall, normally by some random selection of tiles during the installation period in accordance with the Certificate holder's recommendations.

10.5 Vertical rails and other parts of the substructure are outside the scope of this Certificate.

11 Procedure

11.1 The components are prepared and assembled for the job.

11.2 Vertical support rails (outside the scope of the Certificate) are fixed to the substrate at pre-determined centres to suit the wind load (see section 5.2) and thermal requirements (see section 3.5). If top and/or bottom rails are to be used at the top and bottom of the installation, in place of the standard Sigma rail (see Table 2), then additional supports (eg vertical rail offcuts) may be required behind these rails (see section 5.4). Extra supports are also required at the joint between rails (see Figure 4).

11.3 The first rail, normally the bottom one, is positioned horizontally and fixed to the vertical rails ensuring that there is a minimum 19 mm diameter washer between the fixing and the Sigma rail. The fixing, outside the scope of this Certificate, needs to be approved by a suitably qualified engineer.

Figure 4 Typical installation details

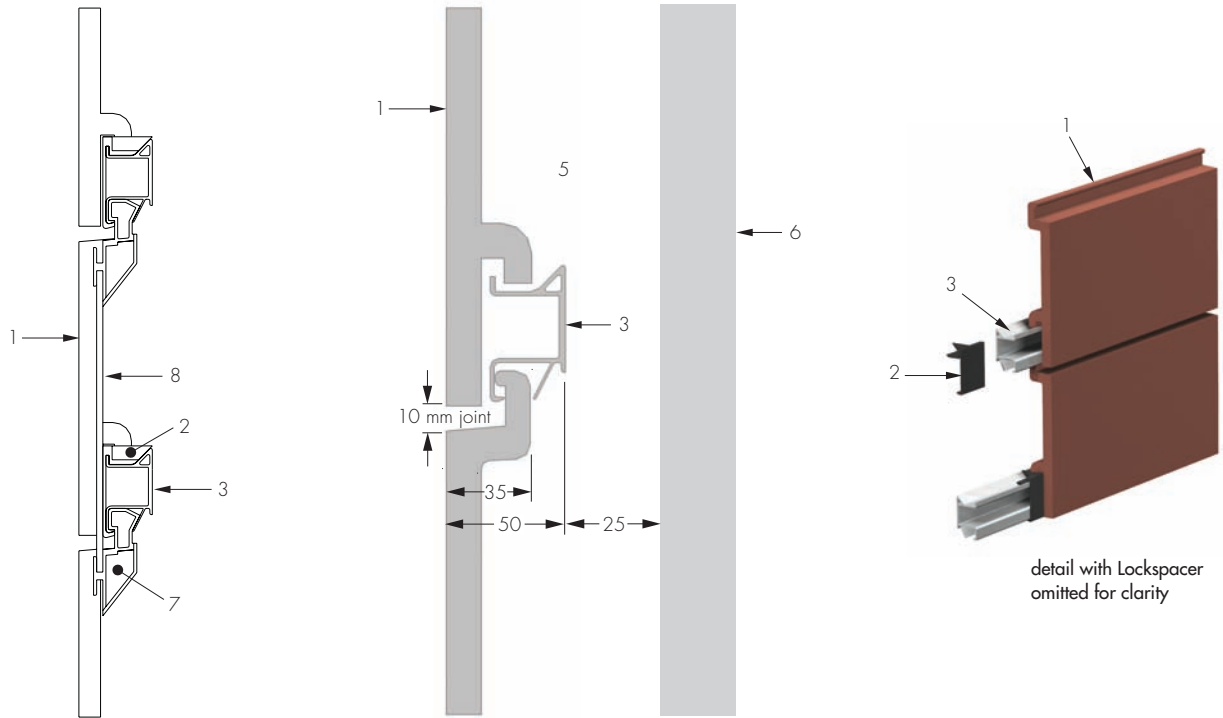

joint with clip, spacer and 8 mm bar

detail with Lockclip and Lockspacer omitted for clarity

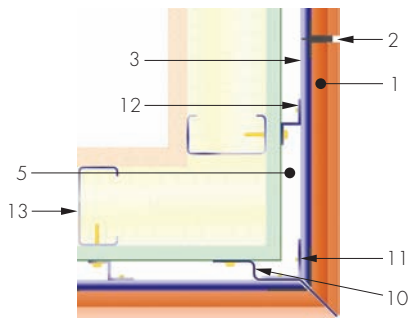

corner detail

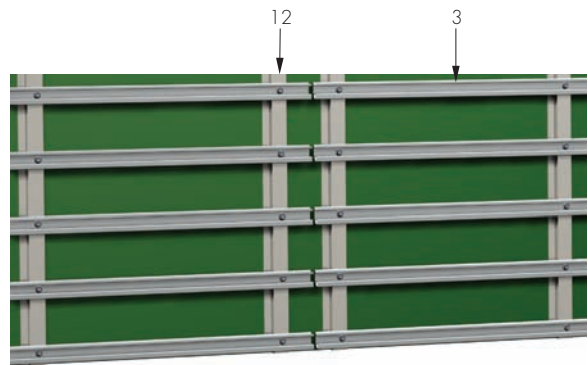

support at rail joints

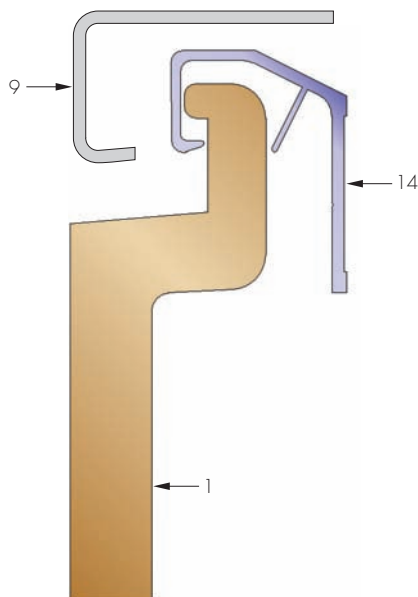

top detail using top rail in place of Sigma rail

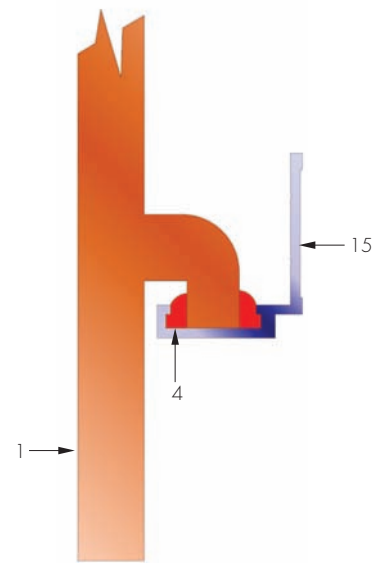

bottom detail using bottom rail in place of Sigma rail

- 1 Locktile
- 2 Lockclip
- 3 Sigma rail
- 4 High modulus silicone sealant
- 5 Ventilated cavity
- 6 Insulation
- 7 Lockspacer
- 8 8 mm spacer bar
- 9 Typical flashing
- 10 Continuous vertical baffle with sealed joints
- 11 Angle bracket
- 12 Vertical rail
- 13 Subframe
- 14 Top rail
- 15 Bottom rail

11.4 The second and subsequent rails are fixed to the vertical rails in the same way using a Lockjig tool to set the vertical spacing (determined by tile height) between rails.

11.5 Adjoining rails need to be carefully aligned, with each end fixed to a separate vertical rail and a 10 mm to 15 mm gap allowed for expansion between rails (see Figure 4). Use, over the join, of a water-resistant adhesive tape, specified by the manufacturer, is recommended to avoid the possibility of splash back to the inner leaf at this junction.

11.6 The tiles are fitted into the rails by inserting the top nib of the tile, at an angle, into the bottom channel of the rail above and straightening the tile so that the bottom nib falls into the upper channel of the rail below.

11.7 The bottom channel on the upper rail can be adjusted with the Lockadjuster tool to give a tight fit on the tile.

11.8 Lockclips are inserted over the lower rail and under the bottom nib of the tile to give a tight fit at the bottom of the tiles. Lockclip 1 includes a 2 mm spacer in the standard clip and sets a 2 mm vertical gap between tiles. Lockclip 2 is the same as Lockclip 1 but without the 2 mm spacer. This is used in conjunction with the Lockspacer tool for the last tile in every row and also used about every fifth tile in a row to allow for subsequent tile removal if required.

11.9 Lockspacers are inserted into the bottom channel of the rail between tiles to reduce splash-back from the rail onto the substructure. Lockspacer 2 has a 2 mm spacer and is used for standard installation with a 2 mm vertical gap between tiles. Lockspacer 8 sets a wider 8 mm gap between tiles. When using this spacer, an 8 mm bar is inserted between adjacent clips in the vertical space between rails to restrict water penetration between tiles at this wider opening. At the top and bottom row of tiles a cross piece, which fits behind the tiles, must be used as a spacer.

11.10 At corners, tiles may be butted or mitred, or used with a trim (outside the scope of this Certificate). The rails should be mitred at the corners and adjoining rails fixed to an angle bracket (which may or may not be fixed back to the substrate).

11.11 At the end of a section, a small mitred return tile or trim may be used.

Technical Investigations

12 Tests

12.1 Tests were carried out on tiles to determine:

- resistance to frost damage
- resistance to impact
- water absorption
- impermeability
- flexural strength
- dimensions.

12.2 Tests were carried out on rails to determine deflection under positive, negative and dead weight loading.

12.3 Tests were carried out on clips to evaluate resistance to weathering and heat ageing.

12.4 Tests were carried out on 2 m square cladding panels to evaluate:

- resistance to the penetration of wind driven rain
- pressure equalisation.

13 Investigations

13.1 An assessment of the practicability of installation was made by reference to the original Lockclad system, covered by Product Sheet 1, and an inspection of the modified components.

13.2 A visit was made to the site of manufacture to evaluate the production and quality control procedures.

13.3 An assessment was made of the behaviour of the product in fire.

Bibliography

- BS 476-6 : 1989 *Fire tests on building materials and structures — Method of test for fire propagation for products*
- BS 476-7 : 1997 *Fire tests on building materials and structures — Method of test to determine the classification of the surface spread of flame of products*
- BS EN 12020-2 : 2001 *Aluminium and aluminium alloys — Extruded precision profiles in alloys EN AW-6060 and EN AW-6063 — Tolerances on dimensions and form*
- BS 6399-2 : 1997 *Loading for buildings — Code of practice for wind loads*
- BS 8200 : 1985 *Design of non-loadbearing external vertical enclosures of buildings*
- BS EN 1991-1-4 : 2005 *Eurocode 1 : Actions on structures — General actions — Wind actions*

14 Conditions

14.1 This Certificate:

- relates only to the product/system that is named and described on the front page
- is granted only to the company, firm or person named on the front page — no other company, firm or person may hold or claim any entitlement to this Certificate
- is valid only within the UK
- has to be read, considered and used as a whole document — it may be misleading and will be incomplete to be selective
- is copyright of the BBA
- is subject to English law.

14.2 References in this Certificate to any Act of Parliament, Statutory Instrument, Directive or Regulation of the European Union, British, European or International Standard, Code of Practice, manufacturers' instructions or similar publication, are references to such publication in the form in which it was current at the date of this Certificate.

14.3 This Certificate will remain valid for an unlimited period provided that the product/system and the manufacture and/or fabrication including all related and relevant processes thereof:

- are maintained at or above the levels which have been assessed and found to be satisfactory by the BBA
- continue to be checked as and when deemed appropriate by the BBA under arrangements that it will determine
- are reviewed by the BBA as and when it considers appropriate.

14.4 In granting this Certificate, the BBA is not responsible for:

- the presence or absence of any patent, intellectual property or similar rights subsisting in the product/system or any other product/system
- the right of the Certificate holder to manufacture, supply, install, maintain or market the product/system
- individual installations of the product/system, including the nature, design, methods and workmanship of or related to the installation
- the actual works in which the product/system is installed, used and maintained, including the nature, design, methods and workmanship of such works.

14.5 Any information relating to the manufacture, supply, installation, use and maintenance of this product/system which is contained or referred to in this Certificate is the minimum required to be met when the product/system is manufactured, supplied, installed, used and maintained. It does not purport in any way to restate the requirements of the Health & Safety at Work etc Act 1974, or of any other statutory, common law or other duty which may exist at the date of this Certificate; nor is conformity with such information to be taken as satisfying the requirements of the 1974 Act or of any statutory, common law or other duty of care. In granting this Certificate, the BBA does not accept responsibility to any person or body for any loss or damage, including personal injury, arising as a direct or indirect result of the manufacture, supply, installation, use and maintenance of this product/system.